

**PRESSURE OPERATED PUMP  
ADCAMAT PPA-14  
DN80 x 50**

**DESCRIPTION**

The ADCAMAT PPA fabricated carbon steel (stainless steel on request) is recommended in the transfer of high-temperature liquids such as condensate, oils and other liquids to a higher elevation or pressure.

The pump starts when there is something to pump and stops when there isn't.

Under certain conditions, it can drain a closed vessel under vacuum or pressure.

The pump can be operated by steam, compressed air or gas and can be used for lifting any kind of non corrosive liquids.

Connections are flanged or female screwed (with screwed flanges).



**OPERATION**

Liquid flows by gravity into the pump through an inlet check valve lifting a float which, at the upper limit of its travel, opens the supply valve which allows steam or compressed air to enter the pump body. Pressure in the pump builds up until just sufficient to overcome back pressure.

The pressurized liquid opens the outlet check valve and discharge commences. When the float reaches the minimum lower level it closes the steam or compressed air supply valve and opens the vent, allowing the liquid to fill the pump again.

As the amount of liquid discharged at each stroke is known, the total volume passed during a given period can be calculated by counting the number of strokes during that period. For this purpose a special counter is available which screws into a tapped connection on the top cover of the pump. This counter records the number of pumping strokes thus enabling the pump to function as a reliable flow meter.

**MAIN FEATURES :** Non-electric requirements.

**OPTIONS:** Duplex packaged design  
Stainless steel construction.  
Level gauge.  
Stroke counter.

**USE :** To lift condensate or hot and cold liquids.

**AVAILABLE MODELS :** ADCAMAT PPA14-S - carbon steel construction (Carbon steel version is sandblasted, metalized and black painted).

**SIZES :** DN 80 x 50

**CONNECTIONS :** Flanged EN1092-1 PN16. Special flanges upon request. Female screwed ISO 7/1 Rp (BS21).

**INSTALLATION :** Horizontal installation.  
See IMI installation and maintenance instructions.

**MOTIVE GAS :** Steam or compressed air.

CE MARKING - GROUP 2 GASES ( PED - European Directive)		
RATING	SIZE	CAT.
PN16	DN 80 x 50	3

**APPLICATION LIMITS**

Minimum density	0,80 kg/dm <sup>3</sup>
Maximum viscosity	5° Engler
Maximum motive pressure	10 bar
Minimum motive pressure	1 bar
Pump discharge per cycle DN100 to DN100	21 l

**LIMITING CONDITIONS \***

PPA-14		
	Press. bar	Temp. °C
PN16	16	50
	14	100
	13	195
	12	250
ANSI Cl.150	16	50
	13	195

Minimum operating temp.: 20°C  
Design code: AD-Merkblatt

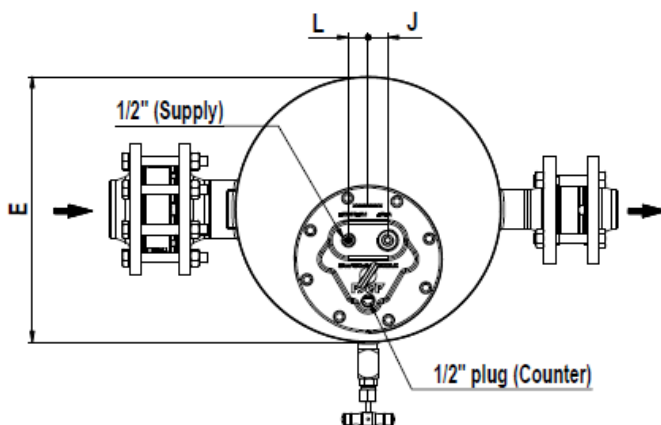
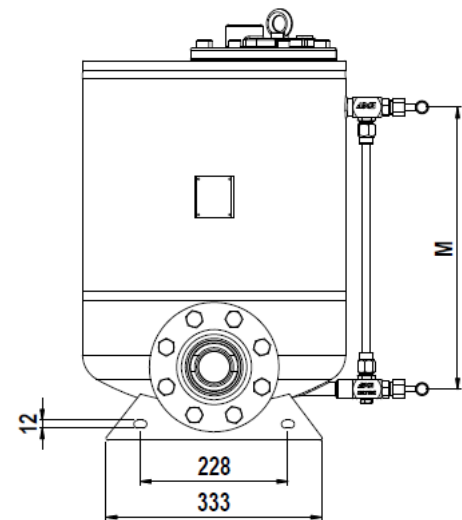
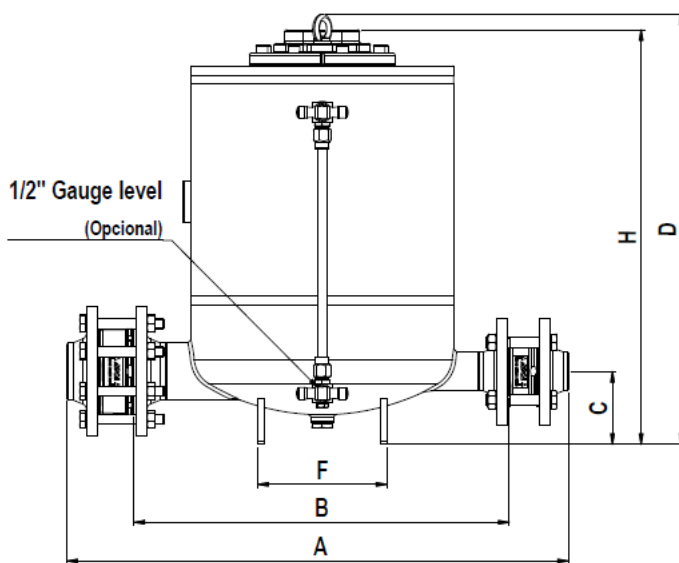

**DIMENSIONS (mm)**

DN	A EN Fig.	A ANSI 150 lbs	B EN Fig.	B ANSI 150 lbs	C	D	E	F	H	J	L	M	Weight Kgs	VOL. dm <sup>3</sup>
80X50	775	847	580	616	113	665	406	200	642	30	30	435	123	68

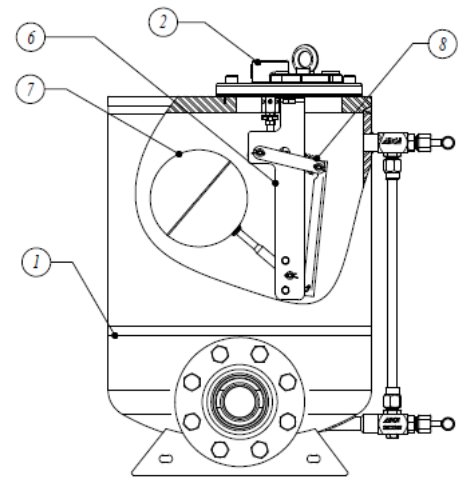
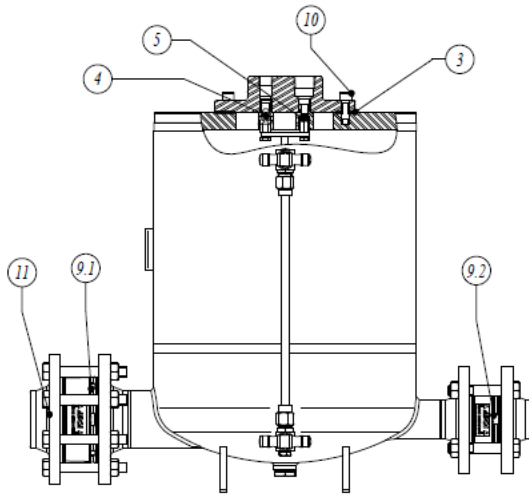

**MATERIALS**

POS.	DESIGNATION	MATERIAL - PPA-S
1	PUMP BODY	P265GH / 1.0425 ; P235GH / 1.0345 S235JR / 1.0038
2	COVER	GJS-400-15 / 0.7040
3	*COVER GASKET	NON ASBESTOS
4	* MOTIVE INLET VALVE/SEAT ASSY	STAINLESS STEEL
5	* EXHAUST VALVE/SEAT ASSY	STAINLESS STEEL
6	INTERNAL MECHANISM	STAINLESS STEEL
7	* FLOAT	STAINLESS STEEL
8	* SPRINGS	INCONEL
9.1	* RD40 INLET CHECK VALVE	CF8M / 1.4408
9.2	* RD40 OUTLET CHECK VALVE	CF8M / 1.4408
10	BOLTS	STEEL 8.8
11	FLANGES	P250GH / 1.0460

\* Available spare parts

\*\* Welding neck flanges. Threaded flanges on request.

**Stroke counter :**

Available on request, it can be screwed directly into the top cover of the pump or above the pump through a 1/2" size pipe for easier reading (max.1m).

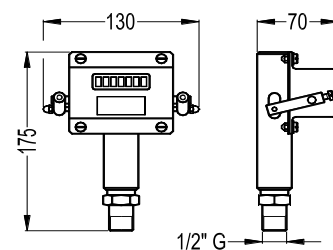

## How to select and size

### SIZING OF THE SYSTEM

The discharge capacity of the pump is a function of:

1. Condensate load.....Kg/h
2. The pressure of operating medium (steam, compressed air or gas).
3. The total lift or back pressure the pump will have to exhaust against. This includes the change in fluid level elevation after the pump (0.0981bar/m of lift), plus pressure in the return piping, plus the pressure drop in bar caused by pipe friction, plus any other system component pressure drop the pump exhaust will have to overcome.
4. Filling head available ( 300 mm is recommended ).

### INSTALLATION – Open system

Fig.1 shows a typical example of installation of ADCAMAT automatic pump. For further details and instructions please contact the factory or our distributor.

### RECEIVER

A receiver is recommended to temporarily hold the liquid and prevent any flooding of the equipment, while the pump is in the pumping cycle. A length of pipe of large diameter or a tank can also be used.

SUGGESTED RECEIVER	
<b>PUMP SIZE</b>	<b>DN 80 x DN 50</b>
<b>RECEIVER SIZE Diam x LENGTH</b>	<b>323 x 1000</b>

Consult the factory for the correct selection

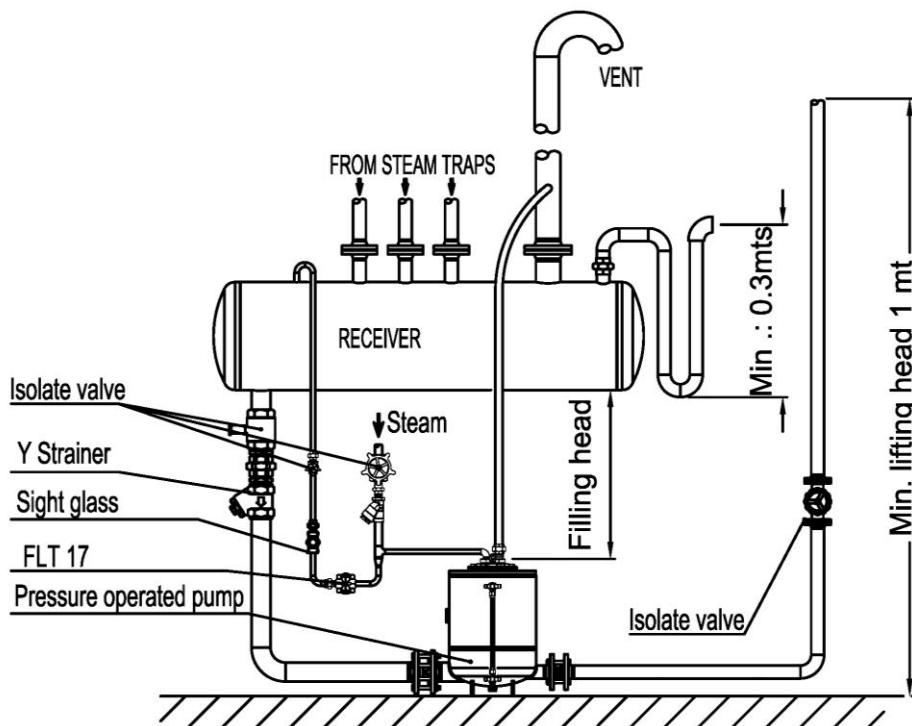

Fig.1

FLOW RATE IN Kg/h Installation with 300 mm filling head above the pump cover.		
Motive Pressure bar	Total Lift bar	DN 80 x 50
1	0,35	3710
1,7		5470
3,5		5820
5		5970
7		6010
10		6290
1,7	1	3570
3,5		5160
5		5360
7		5470
10		5790
2,5	1,5	3435
3,5		4835
5		4980
7		5080
10		5390
3,5	3	2890
4		3440
5		3780
7		4040
10		4430
4,5	4	2505
5		2680
7		2990
10		3385

Chart 1 ( Based on liquid specific gravity 0,9 - 1,0 )  
Filling head is mesured from the bottom of receiver to top of pump cover.

CAPACITY CORRECTION FACTOR FOR GASES OTHER THAN STEAM					
% Back press.vs. Motive Press.(BP/MP)	10%	30%	50%	70%	90%
Correction factor	1,04	1,08	1,12	1,18	1,28

Chart 2

**Example:**

Condensate load	3500 Kg/h
Filling head	150 mm
Motive fluid	Compressed air
Available pressure	7 bar
Vertical lift after pump	10 m
Return piping pressure	1,2 bar
Piping friction pressure drop	Negligible

**Correction for filling Head:**

With 150 mm filling head the correction factor from chart 3 is 0,9. The corrected capacity is, 4040 Kgs/h x 0,9 = 3636 kg/h

CAPACITY MULTIPLYING FACTORS FOR OTHER FILLING HEADS				
PUMP SIZE	FILLING HEAD mm			
	150	300	600	900
DN 80 x 50	0,9	1	1,08	1,2

Chart 3

**Calculations:**

Total back pressure: 1,2bar + ( 10m x 0,0981 ) = 2,181bar  
Pump choice, assuming steam as motive pressure at 7bar and a back pressure of 3bar, the DN80x50 pump has a capacity of 4040 kg/h according to Chart 1.

**Correction for air as a motive fluid:**

The % back pressure 2,181bar/7bar = 31%  
The correction factor from chart 2, is 1,08.  
The corrected capacity is, 3636 kg/h x 1,08 = 3926,88Kg/h, and so a DN80x50 pump is still recommended.